

Wciągnik elektryczny linowy THETA 6300 GNP 1Am

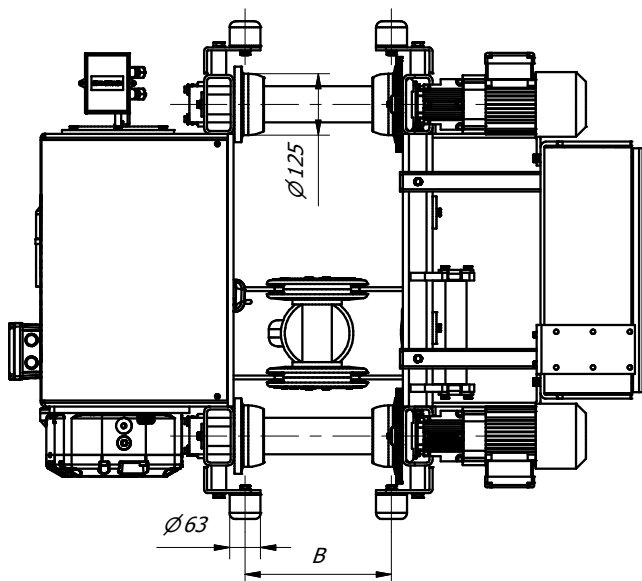
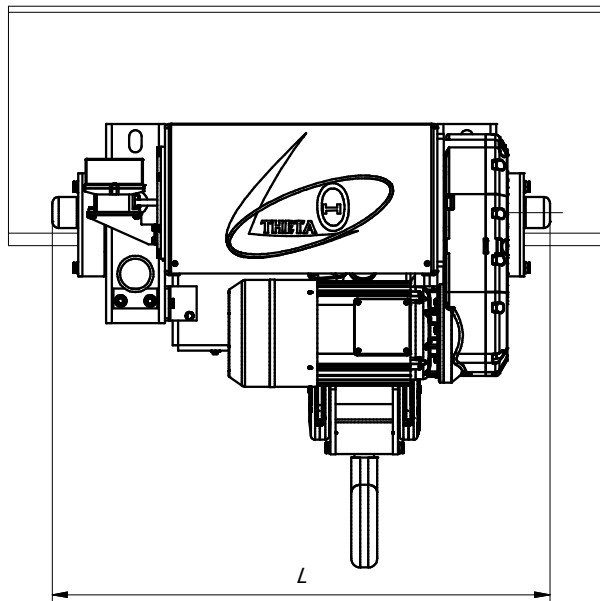
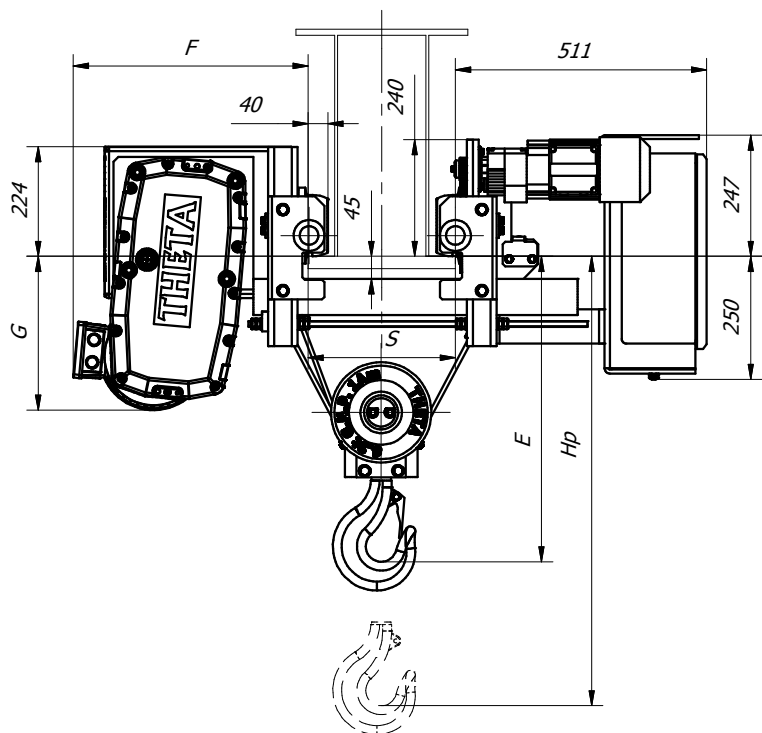

| | vp [m/min] | vj [m/min] | P [kW] | F [mm] | G [mm] | G.N.P. | +m [kg] |
|---|------------|------------|---------|--------|--------|--------|---------|
| A | 4/0,7 | 20/5 | 4,9/0,8 | 478 | 313 | 1Am | - |
| B | 5/0,8 | 20/5 | 6,1/1 | 478 | 313 | 1Am | 9 |
| C | 6,3/1 | 20/5 | 7,7/1,3 | 516 | 338 | 1Am | 52 |
| D | 8/1,3 | 20/5 | 9,8/1,6 | 516 | 338 | 1Am | 60 |

| | TH6306A,B,C,D | TH6309A,B,C,D |
|--------|---------------|---------------|
| Hp [m] | 6 | 9 |
| L [mm] | 1013 | 1223 |
| m [kg] | 370 | 385 |

| S [mm] | 100-250 | 275 | 300 | 325 | 350 | 375 | 400 | 425 | 450 | 475 | 450 |
|-------------|---------|-----|-----|-----|-----|-----|-----|-----|-----|-----|-----|
| E min. [mm] | 570 | 590 | 620 | 640 | 665 | 690 | 710 | 735 | 760 | 785 | 805 |